

Basic Wiring Diagram

Wiring of AC motor drive can be divided into two parts, the main circuit and control circuit. Users must connect terminals as diagram shows.

The following diagram is the standard wiring diagram of series AC motor driver.

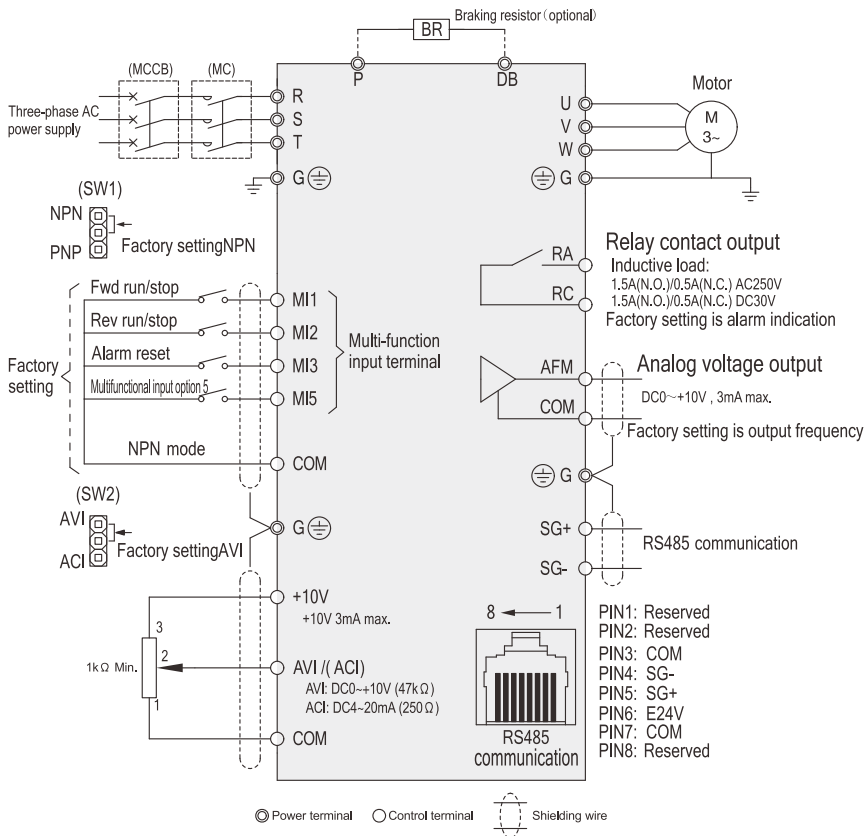

Remarks:

1. Multi-function input terminals MI1~MI3 can switch NPN mode or PNP mode according to SW1, input terminal MI5 NPN mode only.
2. Analog frequency command AVI: It can switch 4~20mA or 0~+10V as input signal according to SW2.
3. When use remote panel, SG+/SG- RS485 serial communication function disabled.